



City of San Bruno
Community & Economic Development Department
Building Division
567 El Camino Real
San Bruno, CA 94066

Phone (650) 616-7074

2022 New Residential Deck Requirements

A complete PDF plan set will be required to submit for a deck permit. See sample deck plan on back:

- **Site Plan:** Site plan shall show all property lines with lot dimensions, proposed deck location, house square footage, street location, setbacks from deck to property lines, existing buildings, fences, retaining walls and height of retaining walls, PUE's, etc.
- **Framing Plan:** Framing plan shall show sizes and type(s) of material, spacing of material, attachment of framing members, and pier locations with details.
- **Elevation Plan:** Elevation plan shall show height of deck from grade at the highest point, deck framing members, deck surface material, guardrail height and attachment.

Deck Requirements:

- All decks over 30" require a 42" high guardrail. The required guardrail shall be designed so that no opening shall allow a 4" sphere to pass.
- Decks shall be designed to carry a minimum of 40 lbs. per square foot live load.
- Deck framing members shall be built out of pressure treated Douglas fir, Cedar, or structural grade Redwood.
- Pier footings for decks shall be a minimum size of 12" x 12" x 12" deep.
- Any deck located in a Wild-Land Urban Interface (WUI). Deck surface shall be of an approved ignition-resistant material.
- Lighting is required at all doors exiting onto deck, at the head of all stairways, and at each landing.
- Safety glass requirements. Plans must indicate where safety glass is required due to size, or proximity to deck or stairs. A receptacle outlet is required at deck areas.

Wood Deck Framing Requirements:

- Where decks are supported by attachment to an exterior wall, they shall be positively anchored to the primary structure. Such attachment SHALL NOT be accomplished by use of toe nails or nails subject to withdrawal
- Deck ledgers shall be a minimum 2 x 8 material made of naturally durable or pressure treated wood.
- Deck ledgers shall not be supported on stone or masonry veneer. (see attachment details)
- The band joist attached by a ledger shall be fully supported by a wall or sill plate below.
- Hold-down tension devices shall be installed in not less than two locations, within 24" of each end of deck. (See details).
- Joist framing at ledger shall be supported by approved hangars.

- Joist framing at beam end shall be connected to beam to resist lateral movement.

Lumber Span Table

Joist Size	Joist Spacing @ 16" o.c.	Joist Spacing @ 24" o.c.	Girder Size	Max Spans
2x6 #2	9'-9"	8'-1"	4x6	6 Ft
2x8 #2	12'-7"	10'-3"	4x8	8 Ft
2x10 #2	15'-5"	12'-7"		

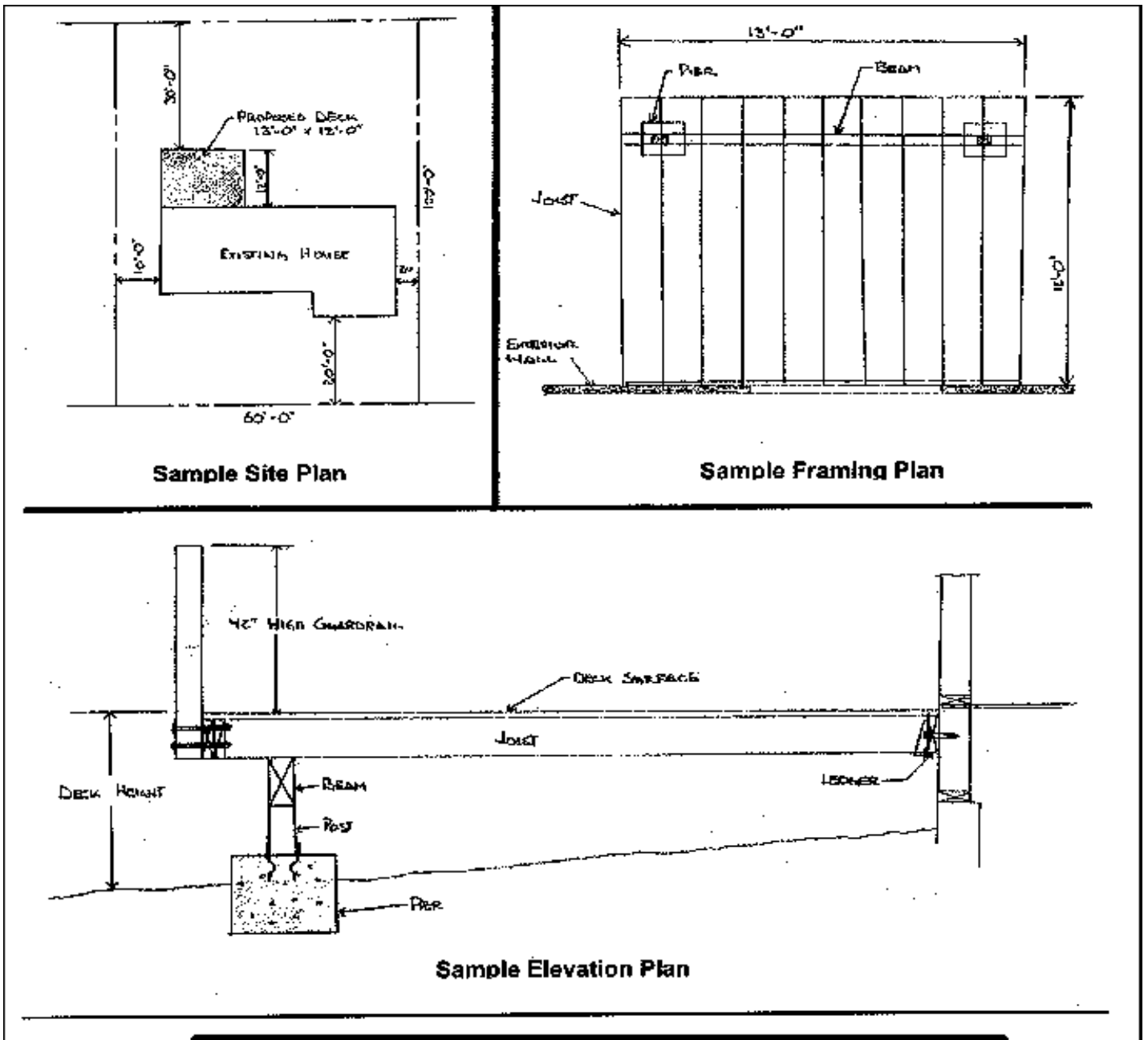

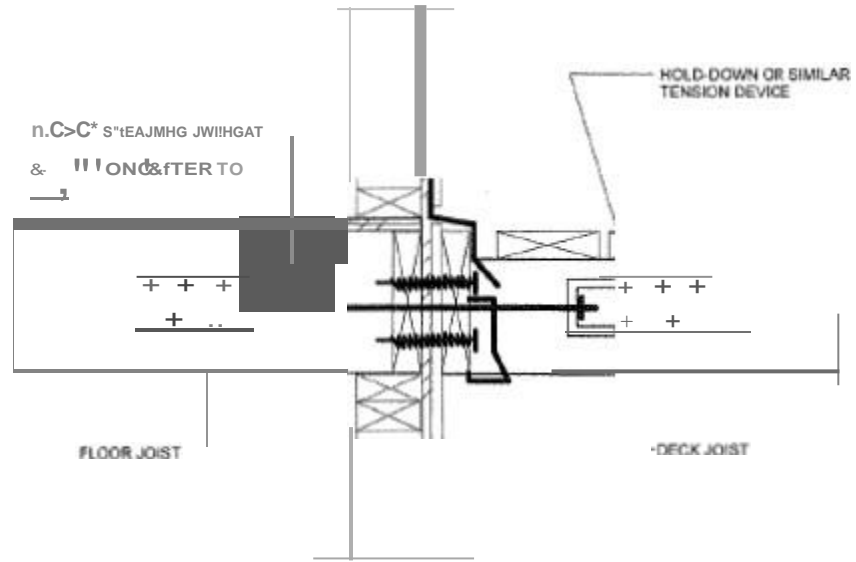

For SI: 1 inch = 25.4 mm

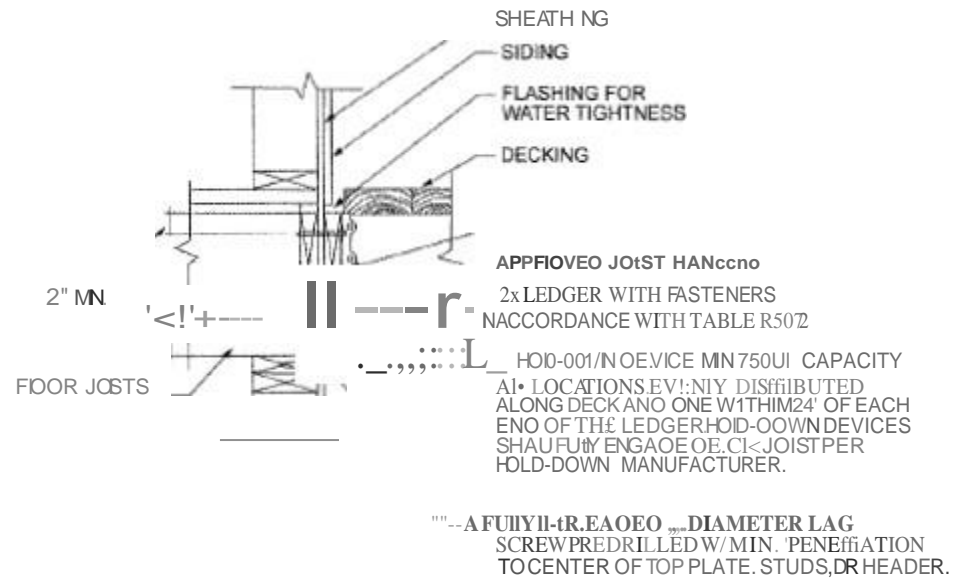

For SI: 1 inch = 25.4 mm, 1 foot = 304.8 mm

FIGURE R507.9.29(2)
 DECK ATTACHMENT FOR LATERAL LOADS

TABLE R507.9.1.3(2)
PLACEMENT OF LAG SCREWS AND BOLTS IN DECK LEDGERS AND BAND JOISTS

MINIMUM END AND EDGE DISTANCES AND SPACING BETWEEN ROWS				
	TOP EDGE	BOTTOM EDGE	ENDS	ROW SPACING
Ledger ^a	2 inches ^d	3/4 inch	2 inches ^b	1 5/8 inches ^b
Band Joist ^c	3/4 inch	2 inches	2 inches ^b	1 5/8 inches ^b

For SI: 1 inch = 25.4 mm.

- a. Lag screws or bolts shall be staggered from the top to the bottom along the horizontal run of the deck ledger in accordance with Figure R507.9.1.3(1).
- b. Maximum 5 inches.
- c. For engineered rim joists, the manufacturer's recommendations shall govern.
- d. The minimum distance from bottom row of lag screws or bolts to the top edge of the ledger shall be in accordance with Figure R507.9.1.3(1).

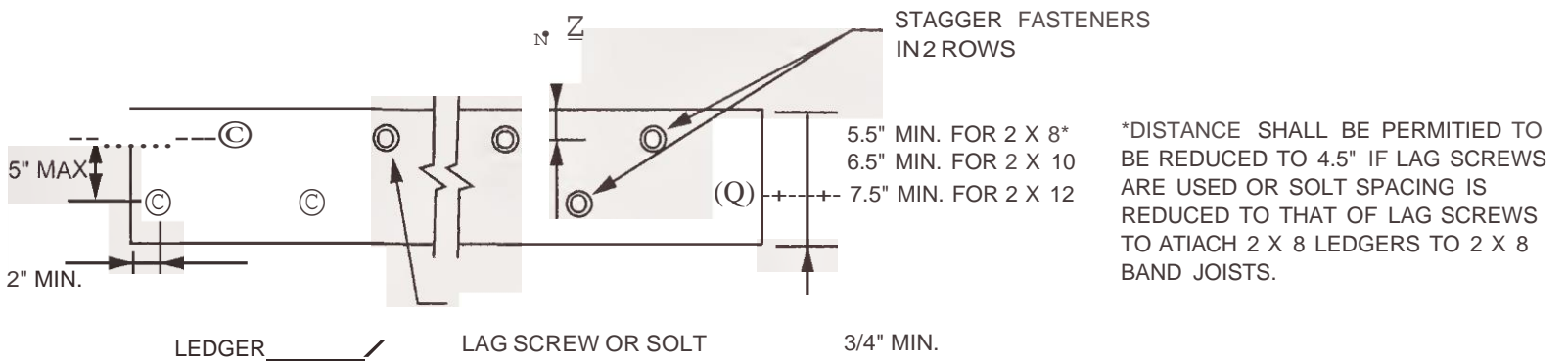

For SI: 1 inch = 25.4 mm.

FIGURE R507.9.1.3(1)
PLACEMENT OF LAG SCREWS AND BOLTS IN LEDGERS

